

ES1 – ECONOMY PRESSURISATION UNIT



Steel chassis finished in epoxy powder paint



18ltr (Actual capacity) break tank. Complying with water regulations 1999, AF air gap.



8 ltr buffer vessel.



Pressure switch pump control



Chassis mounted fused isolation switch



Optional: High & low pressure switches. **(Wiring by others).**

INTRODUCTION

- The ES1 is an economy based unit for the cost conscious project.
- Chassis mounted for either heating or chilled water pressurisation unit, for cold fill pressures up to 2.8bars (28 metres).
- Flow Mech Products Ltd pressurisation equipment automatically controls the pressure in a sealed system delivering water at a pre-determined pressure.
- Once the system has been filled the ES1 will take over and maintain the optimum system conditions.
- Should a loss of water occur in the system, for any reason, the pressure switch will detect the drop in pressure and automatically start the pump, restoring the system to the original cold fill pressure.

SYSTEM CONNECTIONS

- 1/2" BSP connection to float valve.
- 1/2" BSP connection to system.

VESSELS

- Full range of replaceable bag / diaphragm expansion vessels from 3 ltr to 1000 ltr. Rated 99°C & 10bar.

FEATURES

- Adjustable pressure regulating valve, providing steady down stream pressure independent of pump pressure.
- Pressure gauge, displays down stream system pressure.

LOCATION

The unit should be installed in a dry well ventilated position, protected from extremes of heat and cold.

ELECTRICAL CONNECTION

The unit should be connected to a 10 amp fused 230V single phase supply.

DIMENSIONS IN (MM)

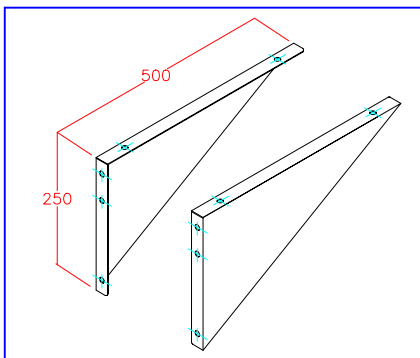
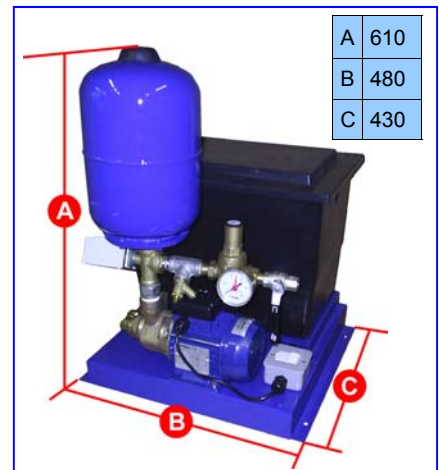

▲ **Optional wall brackets**

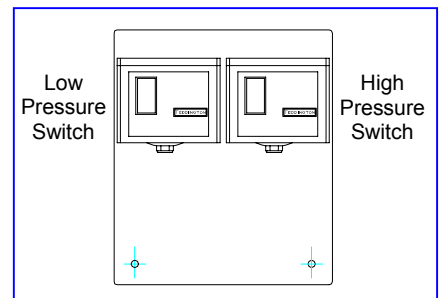

▲ **Optional High/Low Pressure Switches. (Wiring by others).**



AbbeyHouse, CharterStreet, Leicester. LE13UD
 Tel:0116 242 5425. Fax:0116 242 5555
 Email:sales@flowmech.co.uk www.flowmech.co.uk

Vertical Vessels with Legs (mm)		
	A	B
50ltr	365	780
60ltr	380	860
80Ltr	448	840
100Ltr	450	950
150Lt	500	1030
200Ltr	550	1250
300Ltr	645	1380
500Ltr	750	1600

▶ Vertical Vessels with Legs

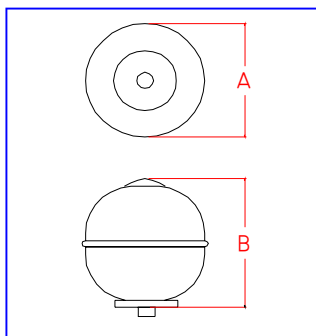
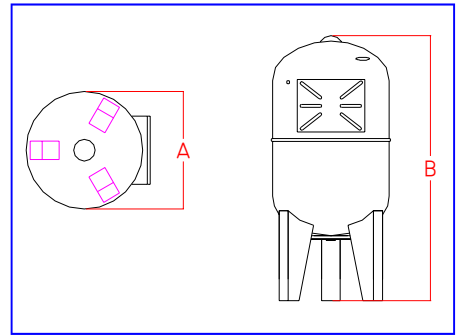

◀ Pipeline Mounted Vessels

Pipeline Mounted Vessels (mm)		
	A	B
3ltr	180	218
8Ltr	225	277
12Ltr	275	277
19Ltr	265	392

Horizontal Vessels (mm)		
	A	B
24ltr	281	495
50Ltr	405	620
60Ltr	405	720
80Ltr	495	660
100Ltr	495	780
150Ltr	535	950
200Ltr	625	1089
300Ltr	680	1237

▶ Horizontal Vessels

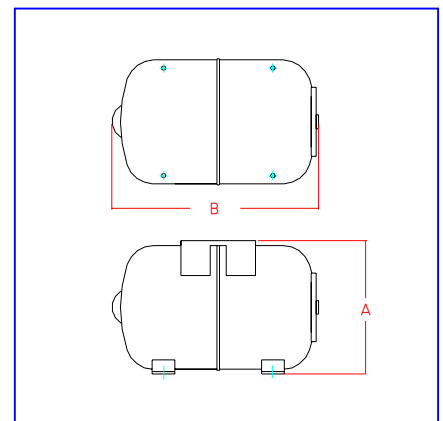

PUMP SPECIFICATION

	Kw	Amps
PUMP	0.47	2.1 (F.L.C.)

MOTOR SPECIFICATION

- Continuous rated.
- Single phase 230V 50Hz, permanently connected capacitor and built in automatic reset overload protection.
- Class F insulation.
- IP44 protection.
- Pump body - Bronze.
- Impeller - Brass.
- Shaft - Stainless Steel



AbbeyHouse, CharterStreet, Leicester. LE13UD
 Tel: 0116 242 5425. Fax: 0116 242 5555
 Email: sales@flowmech.co.uk www.flowmech.co.uk