

VESSELS



GENERAL DESCRIPTION

- These vessels comprise of a steel shell with an internal rubber diaphragm separating the gas and the water spaces. The diaphragm is butyl rubber on the 24 - 100 litre and EPDM on the 19 litre. The shell is coated in an epoxy - polyester powder paint. The vessels are supplied with a stainless steel flange but can be supplied with a galvanised flange on request.

INSTALLATION

- The vessels should be installed in a frost free environment, hung from pipe work (small sizes) or free standing (larger sizes). A drain cock and isolation valve (lockshield type) should be incorporated between vessel and system. The connection should be made to return side of the system on the suction side of the circulating pump. The system connection pipe should be arranged so that any air trapped in the pipe is vented back into the system, rather than accumulating in the expansion tank and also so that no hot water can circulate into the vessel. This means that there should be a rise between the vessel and system connecting point or in the case of pipe hung vessels, these should hang below the main not above.
- The pre charge pressure in the vessel should be adjusted via the Schrader valve to the design value. This may be done with a car type gauge and foot pump or an oil free airline when the vessel is completely empty of water.

MAINTENANCE

- The only maintenance required is to periodically check the pre - charge pressure as detailed above and adjust as necessary.
- It is important that all pipe work is thoroughly flushed out before the vessel is connected as any abrasive matter can cause diaphragm damage.

INSTRUCTIONS FOR REPLACING THE DIAPHRAGM

Replacing the diaphragm on the 24, 50, 60, 80 and 100 litre vessels:

- Reduce the air pressure by operating the air inflation valve (located under the black plastic cap).
- Remove the flange located under the tank.
- Unscrew the lock nut off the air valve so as to release the diaphragm.
- Remove the faulty diaphragm.
- Pick up the air valve and all it's bolts and screws and then refit it on the protuberance of the new diaphragm.
- Replace the diaphragm in the vessel, insert the valve in the hole and than tighten the lock nut.
- Carefully apply the lip of the diaphragm to the ring of the flange downwards making sure that the diaphragm is put correctly into it's position in the vessel taking particular care to see that it is not punctured.
- Refit the flange whilst locking the bolts securely (divide up the locking pressure whilst locking the bolts diagonally).
- Using a sufficiently powerful compressor, pre inflate the tank to 200 grammes below the release pressure of the pressure gauge meter without however exceeding 5 bar.

NB:

- Do not expose the diaphragm to sunlight but keep it in the dark inside the box.
- For further information contact Flow Mech Products Ltd
- All rubber diaphragms are permeable to air so that the pre-charge of the tank should be checked periodically and if necessary brought to the desired pressure.

Replacing the diaphragm on the 100, 200, 300, 500 and 750 Litre vessels:

- Reduce the air pressure by operating the air inflation valve.
- Remove the flange located under the tank.
- Unscrew the nut on the upper part of the vessel so as to release the small supporting flange of the diaphragm.
- Remove the faulty diaphragm.
- Insert the small supporting flange into the new diaphragm (upper part of the diaphragm).
- With a wooden or a similar handle which is at least as high as the vessel on which a nail will be fixed, insert the diaphragm into the vessel and get the small upper supporting flange of the diaphragm (threaded part) to come out through the upper orifice of the vessel. Screw down the bolt on the 1/2" dia. Threaded tube and lock it so that is properly "leak tight". The diaphragm thus remains suspended in the Vessel.
- Carefully apply the lip of the diaphragm to the ring of the flange downwards taking care to see that the diaphragm is correctly located in it's position and is not punctured.
- Refit the flange whilst locking the bolts securely (divide up the locking pressure, locking the bolts diagonally).
- Using a sufficiently powerful compressor, pre inflate the tank to 200 grammes below the release pressure of the pressure gauge meter without however exceeding 5 bar.

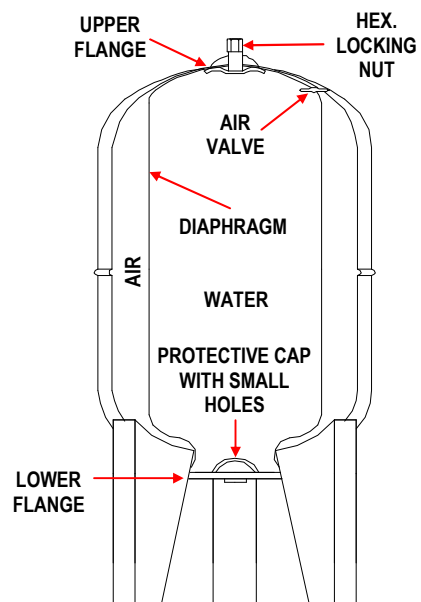
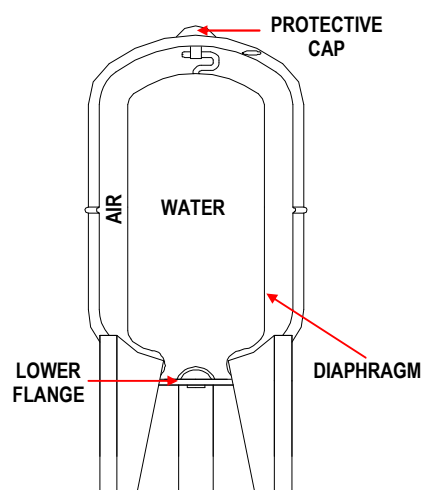

Abbey House, Charter Street, Leicester. LE1 3UD
Tel: 0116 242 5425. Fax: 0116 242 5555
Email: sales@flowmech.co.uk www.flowmech.co.uk

| Vertical Vessels with Legs (mm) | | |
|---------------------------------|-----|------|
| | A | B |
| 50ltr | 365 | 780 |
| 60ltr | 380 | 860 |
| 80Ltr | 448 | 840 |
| 100Ltr | 450 | 950 |
| 150Ltr | 500 | 1030 |
| 200Ltr | 550 | 1250 |
| 300Ltr | 645 | 1380 |
| 500Ltr | 750 | 1600 |

► Vertical Vessels with Legs

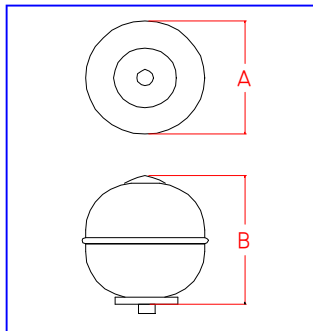
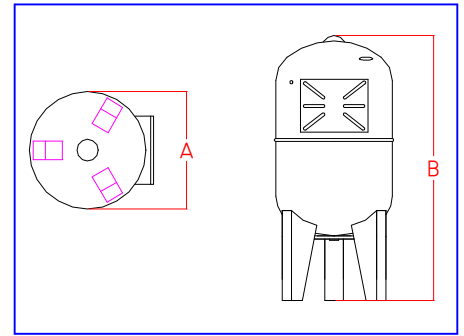

◄ Pipeline Mounted Vessels

| Pipeline Mounted Vessels (mm) | | |
|-------------------------------|-----|-----|
| | A | B |
| 3ltr | 180 | 218 |
| 8Ltr | 225 | 277 |
| 12Ltr | 275 | 277 |
| 19Ltr | 265 | 392 |

| Horizontal Vessels (mm) | | |
|-------------------------|-----|------|
| | A | B |
| 24ltr | 281 | 495 |
| 50Ltr | 405 | 620 |
| 60Ltr | 405 | 720 |
| 80Ltr | 495 | 660 |
| 100Ltr | 495 | 780 |
| 150Ltr | 535 | 950 |
| 200Ltr | 625 | 1089 |
| 300Ltr | 680 | 1237 |

► Horizontal Vessels

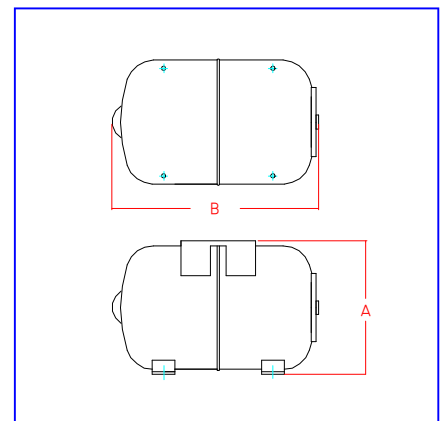

| PUMP SPECIFICATION | | |
|--------------------|------|--------------|
| | Kw | Amps |
| PUMP | 0.37 | 2.5 (F.L.C.) |

- MOTOR SPECIFICATION**
- Continuous rated.
 - Single phase 230V 50Hz, permanently connected capacitor and built in automatic reset overload protection.
 - Class F insulation.

- IP44 protection.
- Pump body - Cast Iron with St./Steel inserts
- Impeller - Brass.
- Shaft - Stainless Steel



AbbeyHouse, Charter Street, Leicester. LE13UD
 Tel: 0116 242 5425. Fax: 0116 242 5555
 Email: sales@flowmech.co.uk www.flowmech.co.uk