

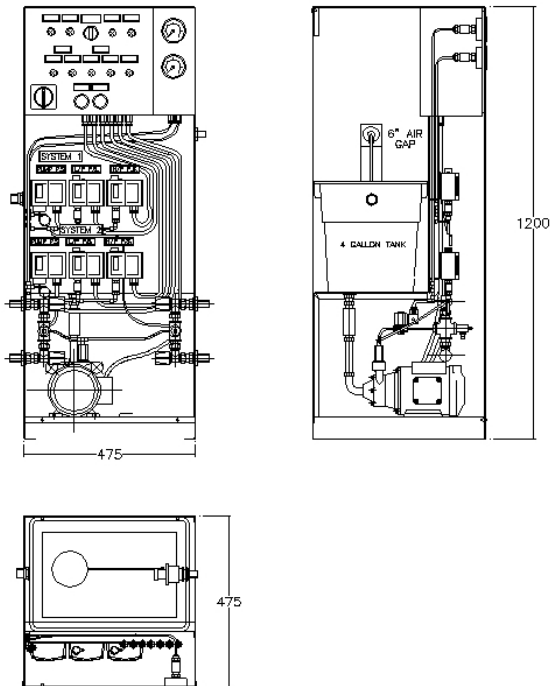





MS2/ENH – PRESSURISATION UNIT



-  Strong 2mm mild steel construction
-  Fully powder coated against corrosion
-  63mm gauge for clear pressure indication
-  Pre-wired high and low pressure switches
-  Lowara PMB 16 Bronze pump
-  Enhanced Electrical Controls

INTRODUCTION

- The MS2/ENH is a single pump, dual system, pressurisation unit designed to control two systems simultaneously.
- For use on heating or chilled water systems up to and including 2.8 Bar cold fill pressures.
- All mounted in a fully enclosed, mild steel powder coated cabinet.
- The unit is designed for ease of installation with all mechanical connections being terminated outside the main shell.

SYSTEM CONNECTIONS

- 1/2" BSP connection to float valve
- 2No. 1/2" BSP connection to system
- 2No. 1/2" BSP connection to vessel
- 22mm overflow connection

PIPEWORK

Suction & discharge internal pipework in copper/plastic capillary tubing, complete with system and vessel isolating valves terminating in 1/2" BSPM screwed connections. System separation is via integral solenoid and check valves.

BREAK TANK

1 No. 4 Gallon polypropylene tank incorporating a 6" air gap from the 1/2" HP float valve and a 22mm compression overflow connection

VESSELS

A Full range of replaceable bag/diaphragm expansion vessels is available to suit all systems.

Ranging from 3 ltr. to 1000 ltr. and rated at 99°C & 10bar.

PUMP

This consists of a stainless steel shaft with bronze impellor & casing. The pump incorporates a self-adjusting mechanical seal.

ELECTRICAL

- Motor: Totally enclosed fan cooled
- Electrical supply: 240 a.c. single phase
- F.L.C.: 2.2 amps
- Power consumption: 300w continuously rated
- Motor insulation: IP44 Class F

ENHANCED CONTROLS

All housed in an IP54 enclosure, the enhanced feature include:-

- Door interlocked isolator
- Power on lamp
- High and low pressure lamps
- Run and trip lamps
- Low water level lamp
- System hand off auto switches
- Duty pump selector switch
- Solenoid control circuit
- Volt free contracts are provided for high and low pressure, pump tripped and low water level



Abbey House, Charter Street, Leicester. LE13UD
 Tel: 0116 242 5425. Fax: 0116 242 5555
 Email: info@flowmech.co.uk www.flowmech.co.uk