







TKS - SINGLE PUMP VARIABLE SPEED BOOSTER SET



-  Designed to provide cold potable water
-  Can be used for domestic , commercial and small industrial purposes
-  Quick & easy installation
-  Compact design
-  IP 55 Protection
-  Quiet running

PUMP

- Stainless steel, end suction pump.
- Motors are T.E.F.C. construction with class IP54 protection.
- 240/1ph/50Hz supply required.

TKS - CEA 80/5/19/D

A	B	C
850	430	275

TKS - CEA 120/5/19/D

A	B	C
850	430	275

TKS - CA 70/33/19/D

A	B	C
860	480	275

TKS - CA 70/44/19/D

A	B	C
860	520	275

OVERVIEW

Ideal for domestic houses, schools, office blocks etc to provide a constant pressure / variable flow of cold water.

The inbuilt inverter adjusts the motor speed to the required system demands via the pipework mounted transducer.

GAUGE

- Complete with a 63mm dial gauge that constantly indicates output pressure.

TEKNOSPEED

The main applications that the TKS single pump booster fits are:

- Domestic
- Irrigation
- Industry
- Commercial

CONNECTIONS

- Suction: 1 1/4" BSP
- Discharge: 1" BSP

Both connections c/w union ballvalves to provide both isolation and serviceability.

INVERTOR FEATURES

- LED lamps indicating status
- Low water cut out feature via optional float switch
- Remote start / stop available (if low level not used)

HYDRAULIC ACCUMULATOR

- 19 litre
- Mild steel construction with powder coating protection complete with replaceable rubber bladder (m.w.p. 10bar) complete with stainless steel flange

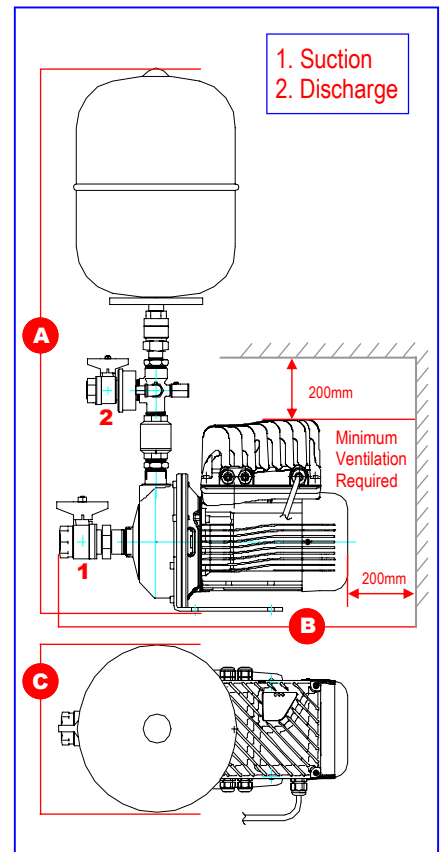

ENERGY SAVING

The pump only consumes the power that is necessary and is eligible for the Enhanced Capital Allowance Scheme (Please see separate Literature).

 **FLOWMECH** *Products Ltd*

Abbey House, Charter Street, Leicester. LE13UD
 Tel: 0116 242 5425. Fax: 0116 242 5555
 Email: sales@flowmech.co.uk www.flowmech.co.uk

TKS - SINGLE PUMP VARIABLE SPEED BOOSTER SET

Performance Curves

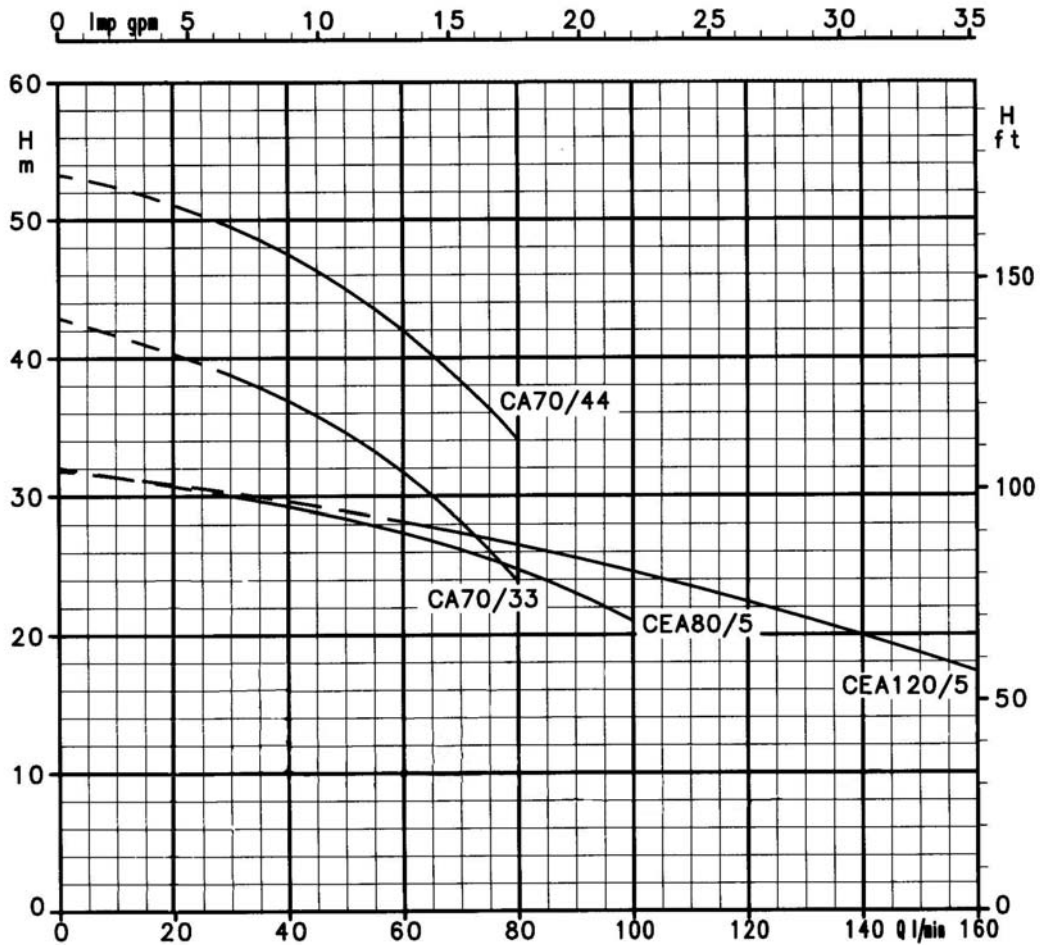

TKS - CEA 80/5/19/D	
KW	AMPS
0.75	4.9
TKS - CEA 120/5/19/D	
KW	AMPS
1.1	6.8
TKS - CA 70/33/19/D	
KW	AMPS
0.75	4.9
TKS - CA 70/44/19/D	
KW	AMPS
1.1	6.8



Abbey House, Charter Street, Leicester. LE13UD
 Tel: 0116 242 5425. Fax: 0116 242 5555
 Email: sales@flowmech.co.uk www.flowmech.co.uk